

BDA Semi-electric Stacker

Operation Manual

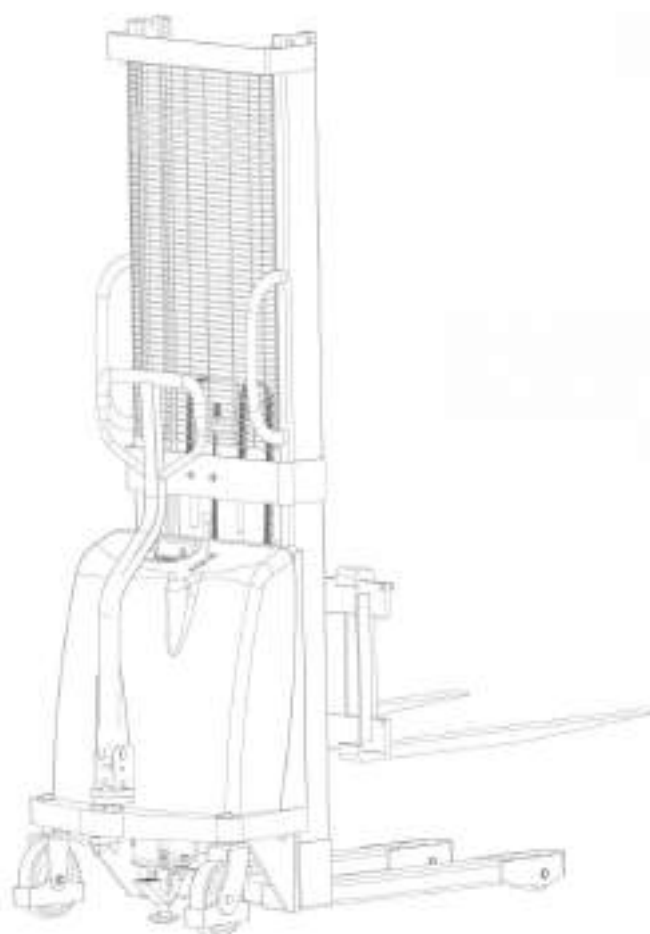

Notes :



Caution

Please pay attention to the following items before using the stacker:

- 1 BDA stacker can only be used indoor with even and solid ground. Circumstance with flammability or causticity such as acerbity and alkali is forbidden.
- 2 Please read the instruction carefully before operating and learn about the performance of stacker. Check the status of the stacker before operation. Don't use the stacker with fault.
- 3 Over loading is forbidden. Loading capacity and load center should comply with the parameter sheet of this instruction.
- 4 When a BDA stacker is used for stow, the center of gravity should be at the range of the two forks.
Please don't use for incompact goods.
- 5 For long distance transportation, the fork height cannot over 0.5m.
- 6 When stowing, people mustn't be under the forks or around the stacker.
- 7 Please don't stand at the forks when work.
- 8 Switch off the power supply after operation.

1. Application

BDA stacker is a kind of economy piling car that uses lead-acid battery as lifting power.

The stacker has the feature of lifting and lowering steadily, easy to operate and maintain, etc. The universal wheel is installed brake for safety and reliably. It is applied to transit and pile small goods. It is an ideal tool to lighten labor intensity, improve production efficiency and realize safe operation.

2. Main technical parameters

Model No.		BDA series
Rated capacity	Q(kg)	1000/1500/2000
Load center	c(mm)	400
Wheelbase	Y(mm)	1145
Service weight (with battery)	kg	265-350
Front wheel dimensions	(mm)	φ80x70
Rear wheel dimensions	(mm)	φ180x50
Lowered mast height	h ₁ (mm)	2088
Lifting height	h ₃ (mm)	1600/2500/3000
Overall height	h ₄ (mm)	2088
Fork lowered height	h ₁₃ (mm)	90
Overall length	l ₁ (mm)	1505
Overall width	b ₁ (mm)	1050
Fork size	s/e/l(mm)	48/100/900
Fork width	b ₅ (mm)	980
Ground clearance	m ₁ (mm)	28
Aisle width, pallet 1000x1200 (1200 crossways)	A _{st} (mm)	1705
Aisle width, pallet 800x1200 (1200 lengthways)	A _{st} (mm)	1755
Turning radius	W _a (mm)	1210
Lifting speed with / without load	m/s	135/150
Falling speed with / without load	m/s	Hand control
Lifting motor power	kW	1.6
Battery voltage / rated capacity	V/Ah	12/(120/135/150)

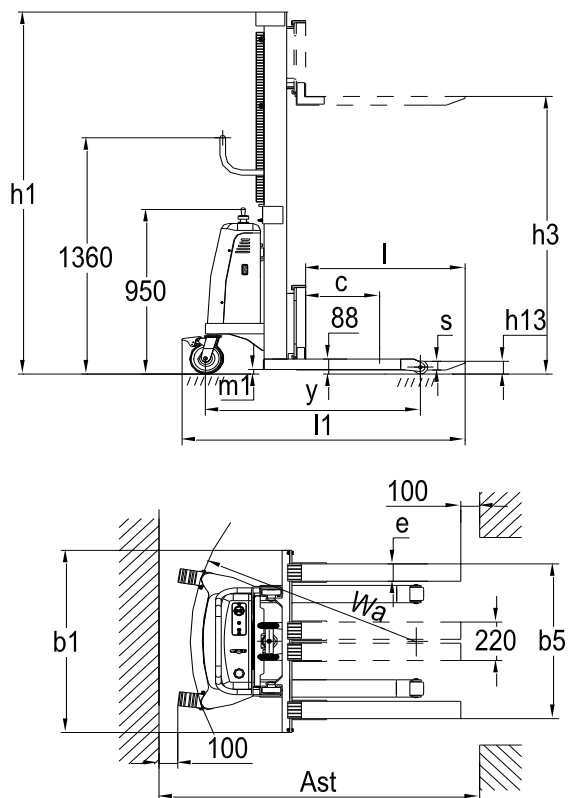

3. Structural features

A BDA Semi-electric stacker is mainly composed of hydraulic system, mast and lifting forks.

- 1 The stacker adopts motor hydraulic system to lift goods, and manpower to push and pull the goods. The hydraulic system consists of the hydraulic pressure stand and oil cylinder, and make the good lift or drop by operating the control lever.
- 2 It is installed with an explosion-proof valve at the bottom of the oil cylinder, to make sure that the forks won't fall rapidly even if the oil tube blows out.
- 3 The gantry is made of 16Mn steel tube with excellent rigidity and light weight.
- 4 The rear wheels are universal wheels with brake, so it can rotate freely, lightly and flexibly.
- 5 It is installed with overdischarge-protect controller of battery, to prevent the battery from being damaged by overdischarging.

4. Service condition

The operation of BDA Semi-electric stacker should meet following conditions:

- 1 Ambient temperature: $-25^{\circ}\text{C} \sim +40^{\circ}\text{C}$.
- 2 Ambient relative humidity: $< 90\%RH$.
- 3 Environment without drench and harmful gas.
- 4 BDA semi-electric stacker is not a kind of blast proof self-protection product, it is forbidden to use in place with inflammable gas.

5. Operation

The operation of BDA semi-electric stacker is very simple.

- 1 Pull the red emergency stop switch and turn the key right to open the electric door lock, if the voltameter light is on, the stacker is in ready mode.
- 2 Pull the control lever, the forks will rise.
- 3 Push the control lever, the forks will drop.
- 4 The falling speed can be controlled by the strength of pushing.
- 5 Brake at the rear wheel is set for the safety of operation, when the forks lift or drop with goods, step down the brake to prevent the wheels rolling.
- 6 When the voltameter appears red indication, you should charge the battery. Or the stacker will take

lifting protection when the last two red lights twinkle alternately. At that time the forks can not lift in order to prevent the accumulator from overdischarge.

- 7 When charging, please press the emergency stop switch and turn off the electric door lock. Plug the charger into the jack at the electrical box side, then connect the electric supply, and open the power switch of the charger.
- 8 After the right connecting of the charger, the stacker charger starts to charge. The POWER indicator on the charger plate lighting shows that the charger is working. CHARGE indicator lighting shows the stacker is in charging state. And the FULL indicator lighting shows the charging finished.
- 9 The hydraulic oil must be filtrated, and keep the pump enough oil. Replace the oil according to the use degree and the clean condition of the hydraulic oil. Hydraulic oil must be LHPISOVG46 that conforms to DIN51524T.2 Standard.
- 10 After working, discharge loading. Don't let weight stay on the forks for a long time.

6. Possible faults and solutions

No.	Faults	Causes	Solutions
1	The voltameter has no signals when power on.	The 10A fuse of the top broke off or supply switch damaged.	Replace the fuse or supply switch.
2	It cannot reach the designed lifting height.	Lack of hydraulic oil.	Add hydraulic oil.
3	There's noise from motor pump in the hydraulic station, but the forks cannot lift or fall.	There's block at the solenoid valve core.	Remove it and clean with gasoline or kerosene.
4	When power is on, the coulomb meter shows the number, but the forks don't work.	175A fuse in lifting loop broke off or the battery-protect controller damaged.	Replace the fuse. If it broke off again, check the loop and see if there's any open circuit or bad elements.
5	Oil impregnate or leak.	Seal washer damaged or screw joint loosened.	Replace a new seal washer or screw down.

7. Use, maintenance and charge of the batteries

7.1 Initial charge

Note: The charging environment requires good ventilation and there should be no flame, otherwise explosion may occur.

7.1.1 Initial charge should be conducted for batteries that have never been used. Before the initial charge, the surface of the batteries should be cleaned and the batteries should be checked whether have damage. The bolts should be tightened to ensure reliable connection.

7.1.2 Pull out the sealing cover and replace it with the open cover type liquid hole plug and open the cover.

7.1.3 Pour the sulfuric acid electrolytic solution with a density of $1.260 \pm 0.005(25^{\circ}\text{C})$ and a temperature below 30°C into the batteries while the charging equipment is able to operate normally. And the liquid surface should be 15 ~ 25 (mm) higher than the protective board. In order to reduce the temperature rise out of chemical reaction of the electrolytic solution and let the solution penetrate into the pores of the polar plates and the baffles, the batteries should be placed still for 3~4 hours, no longer than 8 hours. The initial charging can only be conducted when the temperature of the solution reduces to below 35°C . (If necessary, the batteries can be put into cold water for temperature reduction.) After the still placement, electrolytic solution should be added if the surface of the solution descends.

7.1.4 The sulfuric acid electrolytic solution is prepared with battery sulfuric acid complying with the state standard GB4554-84 and distilled water. Never substitute industrial sulfuric acid and running water for that. The standard temperature (25°C) and density of the electrolytic solution can be converted as following formula:

$$D_{25} = D_t + 0.0007(t - 25)$$

Here: D_{25} is the density of the electrolytic solution at 25°C .

D_t is the actual density of the electrolytic solution at $t^{\circ}\text{C}$.

t is the electrolytic solution temperature while testing the density.

7.1.5 Sweep the electrolytic solution on the surface of the batteries, connect the positive and the negative poles of the battery group respectively with the positive and the negative ends of the DC power supply (charger).

7.1.6 Fully charged basis: BDA stacker uses the intelligent charger, and it will stop charging once it is fully charged. (First charging time is relatively longer, and the conventional charging time is 10-12 hours.)

7.1.7 In order to accurately control the sulfuric acid content of the electrolytic solution, the electrolytic solution density of the batteries should be examined during the last period of charging. If it is inconsistent, please adjust with distilled water or sulfuric acid with a density of 1.40. The electrolytic solution density and the liquid surface should be adjusted to the stipulated value within two hours in the charging state.

7.1.8 After the initial charging is completed, the surface of the batteries should be cleaned. Close the cover of the open cover type liquid hole plug and only then the batteries can be used.

7.2 Use and maintenance

7.2.1 In order to guarantee the service life of the batteries, all the batteries in use should be fully charged. Insufficiently charged batteries must not be used. During the process of use, close attention should be paid to the discharge extent. Over discharge is forbidden-the voltage reduces to 1.8V per battery. (when the total voltage reduces to $1.8V \times 6 = 10.8V$) When the density of the electrolytic solution reduces to 1.17, discharging should be stopped and charging should be conducted at once. The batteries should not be placed idle for a long time. The supplementary charging frequently conducted during the process of use is called common charge.

7.2.2 Common charge: The charging method is the same as that of initial charge. The charged volume is 130-140 % of the discharged volume and the charging time is about 12 hours.

7.2.3 The batteries in normal use should avoid over-charge, but over-charge must be properly conducted if the batteries are in following situation, balance charge.

a. The "lag-behind" batteries--- batteries with a voltage lower than that of the other batteries in the discharging process and the batteries having been repaired for failure. (When balance charge is conducted, the positive and negative poles of the "lag-behind" battery should be respectively connected with the positive and negative ends of the DC power supply, and the charge should be

conducted independently.).

b. Balance charge should be conducted for the batteries in normal use every 2-3 months.

c. Balance charge should be conducted for the batteries that have not been used for a long time before use.

7.2.4 Balance charge :

a. Charge with a 4A current

b. When the charge voltage reaches 14.6V ($6 \times 2.6V = 14.6V$) and air bubbles occur in the electrolytic solution, the current should be reduced by 50% (2A) and continue to charge.

c. When the batteries are in the state of fully charged, stop for 0.5 hour and charge again with a 1A current for one more hour.

d. Stop for another 0.5 hour and charge with a 1A current for another one hour.

e. Repeat according to item d till air bubbles occur violently in the batteries once the charger is switched on.

7.3 Storage

7.3.1 Batteries should be stored in a clean, dry and well ventilated warehouse with a temperature of 5-40°C. The valid shelf life is 2 years. The batteries should be kept according to the following requirements during storage.

a. No direct sunshine on the batteries and at least 2m away from heat source.

b. Avoid contacting with any harmful substances. No metallic matters are allowed to drop into the batteries.

c. It is forbidden to put the batteries upright down, and avoid any mechanical impact or heavy load.

d. The batteries must not be stored with electrolytic solution. When it is required in special situation that the batteries must be stored with electrolytic solution, the batteries should be fully charged, meanwhile the density and the liquid surface of the batteries should be adjusted to the rated values. When the storage expires a month, the batteries should be complementarily charged with the common charging methods.

8. Major parts structure chart (explosive view) , schematic

- 1. Explosive view**
- 2. Hydraumatic schematic**
- 3. Electrical equipment schematic**

1.1.Final assembly

No.	Description	Material code	Qty.
1	Mesh enclosure	BDA-00004	1
2	Fixed climb	BDA-00001	4
3	Bolt M6x12	T-LD-006	4
4	Back cover	BDA-00028	1
5	Battery (12V/120Ah)	BDA-00027	1
6	Hydraulic station 12V/1.6KW	BDA-00023	1
7	Hexagon socket head cap screws M10x20	T-LD-086	2
8	Pin roll Φ20*81	BDA-00006	1
9	Shield d20	T-DQ-004	6
10	Brake assembly	BDA-00029	1
11	Hexnut M10	T-LM-001	4
12	Universal wheel assembly	BDA-04036	2
13	Wheel Φ180*50	SBA-00061	2
14	Lining Φ20*Φ12*55	BDA-04031	2
15	Deep groove ball bearing 60204	T-ZC-007	4
16	Bushing	BDA-04030	2
17	Outer hexagon bolt M12*93	T-LD-003	2
18	Locknut M12	T-LM-003	2
19	Fork assembly	BDA-B7000	1
20	Battery connector CHJ-2/50A	DQ-020	1
21	I-shape nonmetal inserts locknut M3	T-LM-007	2
22	Hexagon socket head cap screws M3*25	T-LD-044	2
23	Nylon fork wheel Φ80x93	SBA-00022	2
24	Deep groove ball bearing 60204	T-ZC-007	4
25	Lining	BDA-04030	2
26	Front wheel axle Φ20*123	BDA-00017	4
27	Outer hexagon bolt M10*25	T-LD-010	4
28	Mast welding assembly	BD-05001	1
29	Cross-shaped sunk screw M5X10	T-LD-045	2
30	Emergency stop switch	DQ-030	1
31	Round voltameter BI1201B	DQ-029	1
32	Electric door lock 25VDC/10A	DQ-031	1
33	Outer hexagon bolt M10*45	T-LD-052	4

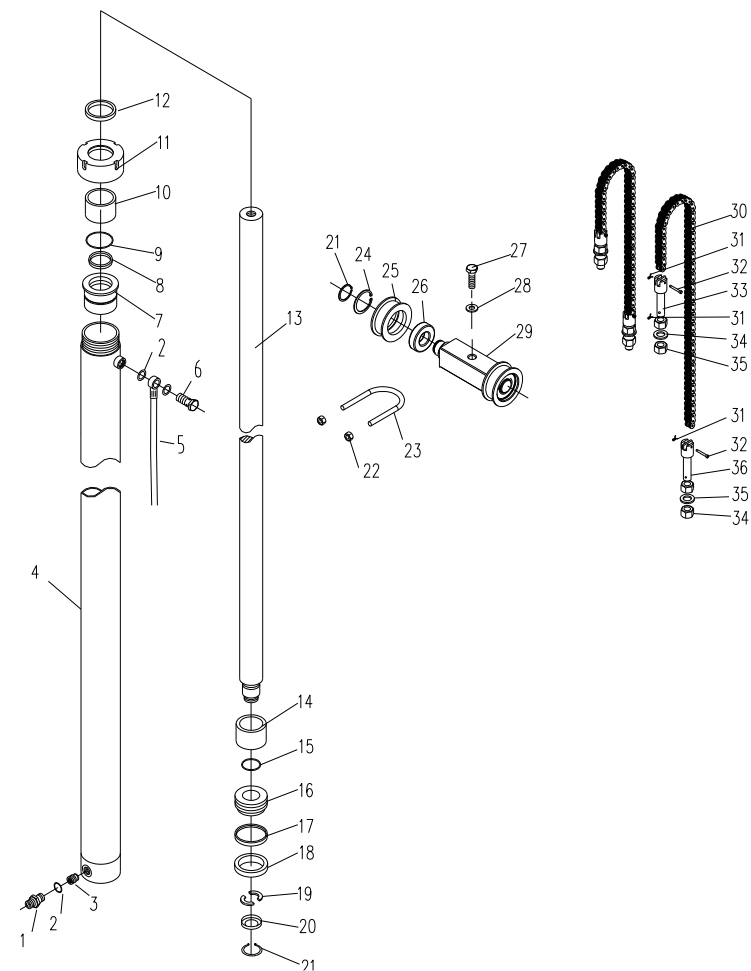
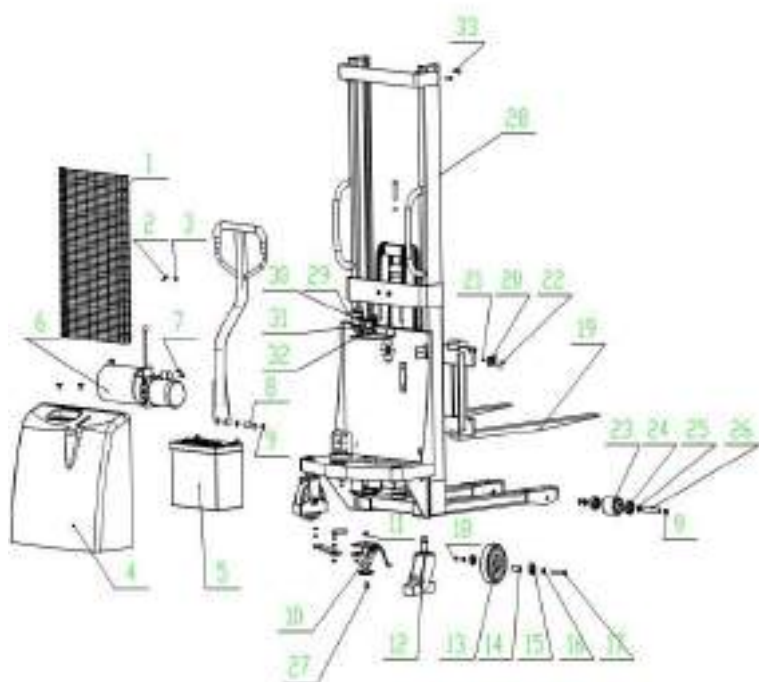

1.2.Hydro-cylinder assembly

No.	Description	Material code	Qty.
1	Enlarge mouth type pipe joint body M14*M14*39	BDA-03021	1
2	Combined seal washer Φ14	T-DP-010	3
3	Explosion-proof valve	BDA-03018	1
4	Hydro-cylinder	BDA-03009	1
5	Oil return pipe	BDA-00022	1
6	Return opening connector M14*32	BDA-00024	1
7	Guide liner	BDA-03004	1
8	UHS seal ring Φ40×50×6	T-MF-003	1
9	O-shape seal ring Φ50×3.55	T-MF-002	1
10	Composite liner SF-1 4030	T-ZC-025	1
11	Hood	BDA-03003	1
12	DH dust-proof ring Φ40	T-MF-001	1
13	Piston rod	BDA-03010	1
14	Lining	BDA-03011	1
15	O-shape seal ring Φ23.6×3.55	T-MF-004	
16	Piston	BDA-03013	1
17	Guide ring	BDA-03014	1
18	UHS seal ring Φ45×56×7	T-MF-005	1

No.	Description	Stock code	Qty.
19	Half ring	BDA-03016	2
20	Half ring cover	BDA-03017	1
21	Circlip for shaft Φ30	T-DQ-005	3
22	Nonmetal inserts nut M10	T-LM-004	2
23	Hydro-cylinder embrace climb	BDA-00003	1
24	Circlip for hole Φ62	T-DQ-006	2
25	Chain wheel	BDA-03032	2
26	Deep groove ball bearing 60026	T-ZC-004	2
27	Hexagon socket head cap screws M16×95	T-LD-011	1
28	Flat washer 16	T-DP-007	1
29	Chain wheel	BDA-03031	1
30	Plate-type wheel	T-QT-011	2
31	Cotter Φ2*16	T-XZ-002	6
32	Chain shaft	BDA-03040	4
33	Flatment stem	BDA-03041	2
34	Flat washer Φ16	T-DP-007	4
35	Hexagon nut M16×1.5	T-LM-008	1
36	Short stem	BDA-03039	2

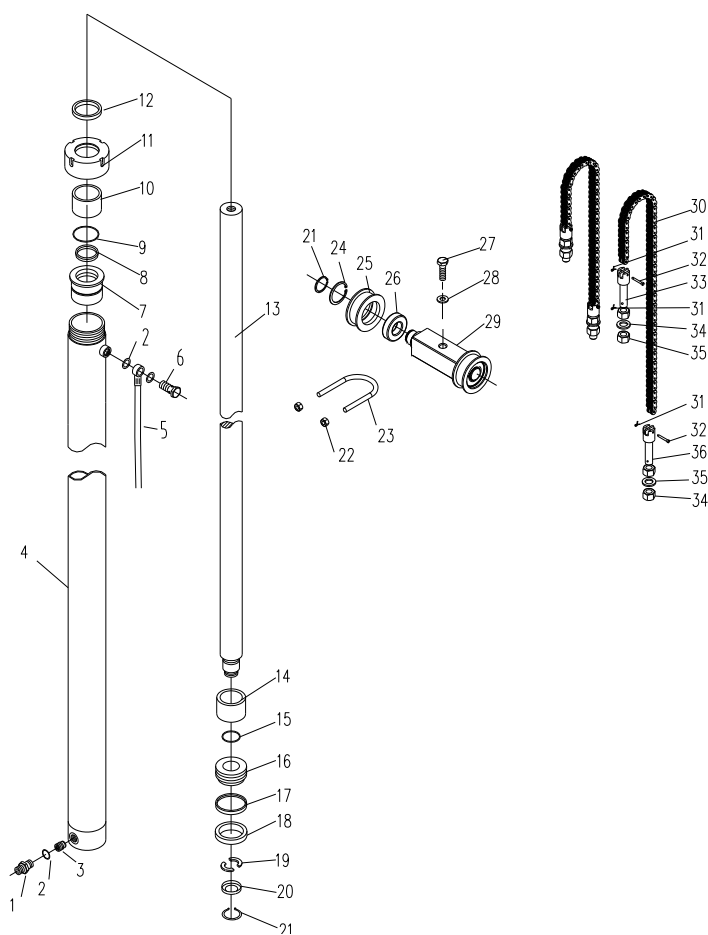

1.3. Fork assembly

No.	Description	Material code	Qty.
1	Lift table	SDA-07001	1
2	Hexagon socket set screw with flat end M16×50	T-LD-004	4
3	Circlip for hole Φ72	T-DQ-001	4
4	Deep groove ball bearing 60207	T-ZC-001	4
5	Roller Φ106×32	BDA-06007A	4
6	Circlip for shaft Φ35	T-DQ-002	4
7	Hexagon socket head cap screws M6*16	T-LD-006	1
8	Steel ball ϕ 19.05	T-QT-010	4
9	Plate-type movable fork	BDA-07015	2

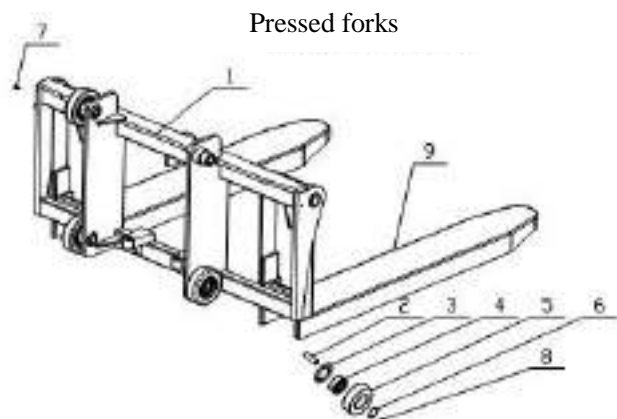

No.	Description	Material code	Qty.
1	Lift table	SDC-07001	1
2	Hexagon socket set screw with flat point M16×50	T-LD-004	4
3	Circlip for hole Φ72	T-DQ-001	4
4	Deep groove ball bearing 60207	T-ZC-001	4
5	Roller Φ106×32	BDA-06007A	4
6	Circlip for shaft Φ35	T-DQ-002	4
7	Locknut M10	T-LM-004	2
8	Hexnut M10	T-LM-001	2
9	Hexagon bolt M10*45	T-LD-013	2
10	Forging fork	SDC-07010	2
11	Steel ball ϕ 19.05	T-QT-010	4

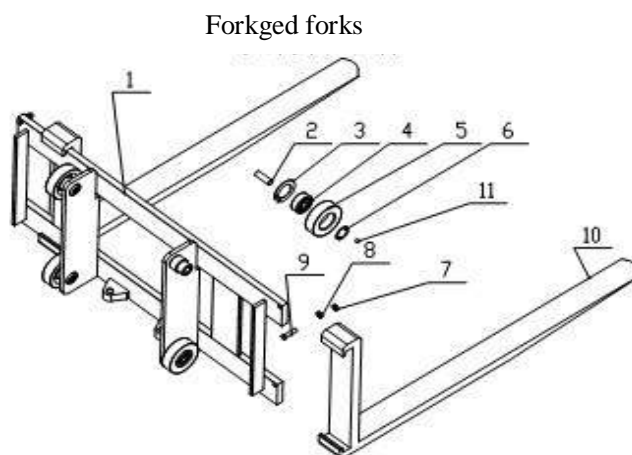

2. Hydrametic schematic diagram

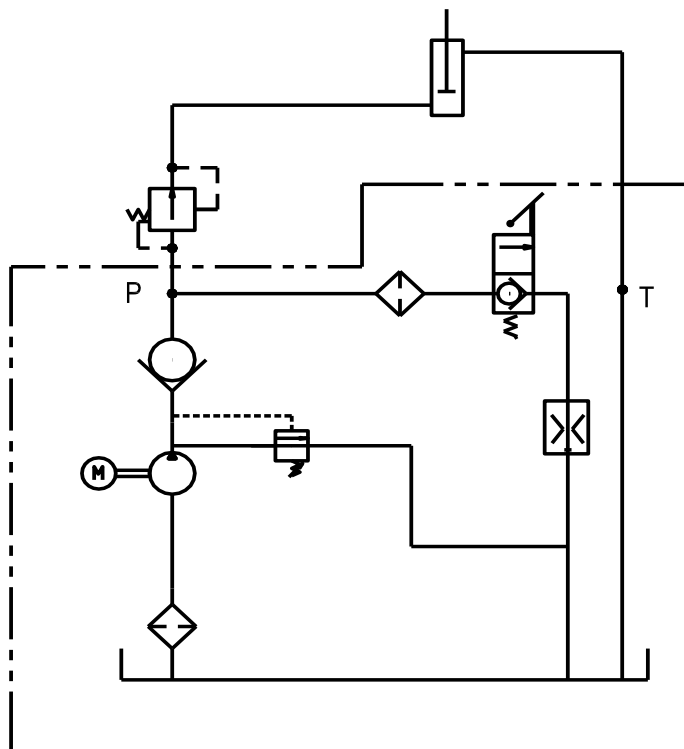

3. Electrical schematic diagram

